



深圳市高信技术有限公司

Shenzhen G&X Technology Co., Ltd

SPECIFICATION FOR LCD MODULE

Customer : _____
CustomerP/N _____
Model No. : GX024-40RB-A1
Version : V01
Date : 2023-05-29

Final Approval by Customer

Approved by	Notes

ShenZhen GX Confirmed :

Prepared by	Checked by	Approved by



Table of Contents

Revision History	3
1 General Specifications	4
2 Pin Assignment	5
3 Absolute Maximum Ratings	6
4 Electrical Characteristics	6
5 INTERFACE TIMING	9
5.1 System Bus Read/Write Characteristics	9
5.2 Power ON/OFF Timing	10
6 Optical Characteristics	13
7 Environmental / Reliability Test	17
8 Mechanical Drawing	18
9 Precautions For Use of LCD Modules	19



Revision History

Rev	Issued Date	Description	Page	Editor
1.0	Dec. 17, 2020	First release	All	



深圳市高信技术有限公司

Shenzhen G&X Technology Co., Ltd

1 General Specifications

	Feature	Specifications
Display Spec.	LCD type	2.4 inch
	Resolution (H*V)	222(RGB) ×480
	Technology Type	a-Si TFT
	Pixel Configuration	R.G.B. Vertical Stripe
	Display Mode	Normally Black
	Viewing Direction	ALL
	Gray Scale Inversion Direction	-
Mechanical Characteristics	OutlineDimensions (W x H x T) (mm)	30.3*63.11*2.15
	Active Area(mm)	25.51*55.15
	CTP View Area(mm)	\
	With /Without Touch screen	Without CTP
	Connector Type (for LCD)	0.5mm pitch 40pin ZIF
	Backlight Type	LED
	Weight (g)	TBD
Electrical Characteristics	Display Interface	SPI+RGB 18bits
	Touch Interface	/
	Number of color	262K
	Display Driver IC	ST7796U
	Touch Driver IC	/



2 Pin Assignment

1	LED A	LED ANODE
2	LED K1	LED CATHODE
3	LED K2	LED CATHODE
4	GND	Ground
5	VCI	Power supply (+3.3V)
6	RESET	Reset Signal ,Active Low
7	IM1	Not connection
8	IM0	Not connection
9	SDA	SPI Data signal
10	SCK	SPI Clock signal
11	CS	SPI Chip select signal
12	PCLK	RGB dot clock signal
13	DE	RGB data enable signal
14	VSYNC	RGB frame synchronizing signal
15	HSYNC	RGB line synchronizing signal
16~33	DB0~DB17	RGB data signal (DB0: Blue LSB; DB5:Blue MSB; DB6: GREEN LSB; DB11: GREEN MSB; DB12: RED LSB; DB17: RED MSB)
34	GND	Ground
35	TP_INT	Not connection
36	TP_SDA	Not connection
37	TP_SCL	Not connection
38	TP_RESET	Not connection
39	TP_VCI	Not connection
40	GND	Ground



3 Absolute Maximum Ratings

GND=0V, Ta= 25°C

Item	Symbol	Value	Unit
Operating temperature	Topr	-20 to 70	°C
Storage temperature	Tstg	-30 to 80	°C

Note: Note1: Absolute maximum rating is the limit value beyond which the IC maybe broken.

They do not assure operations.

Note2: Background color changes slightly depending on ambient temperature. This Phenomenon is reversible.

Ta ≅ 70°C: 75%RH max

Ta > 70°C: absolute humidity must be lower than the humidity of 75%RH at 70°C

Note3: Ta at -30°C will be <48hrs, at 80 °C will be <120hrs

4 Electrical Characteristics

4.1 Driving TFT LCD Panel

Item	Symbol	Min	Typ	Max	Unit	Remark
Analog power supply	VCI	2.5	2.8	3.6	V	
Power consumption	Ivci	60	70	75	mA	



4.2 Driving Backlight

Ta=25°C

Item	Symbol	Min	Typ	Max	Unit	Remark
Forward Current	I_F	--	60	-	mA	
Forward Voltage	V_F	-	3.2	-	V	
Connection mode		--	4P	--		
LED number	/		4		pcs	

Note1: Optical performance should be evaluated at Ta=25°C only .If LED is driven by high current, high ambient temperature & humidity condition. The life time of LED will be reduced. Operating life means brightness goes down to 50% initial brightness. Typical operating life time is estimated data.

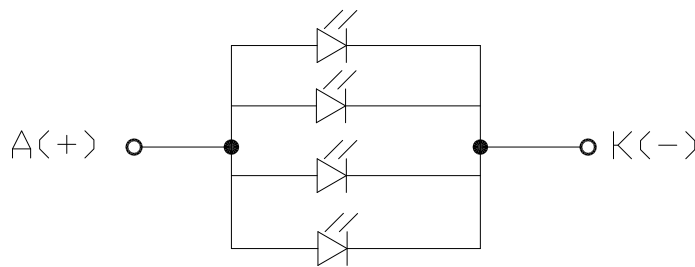

背光电路图 (CIRCUIT DIAGRAM)

$I_F=60\text{mA}$, $V_F=3.2\text{V}$



4.3 Block Diagram

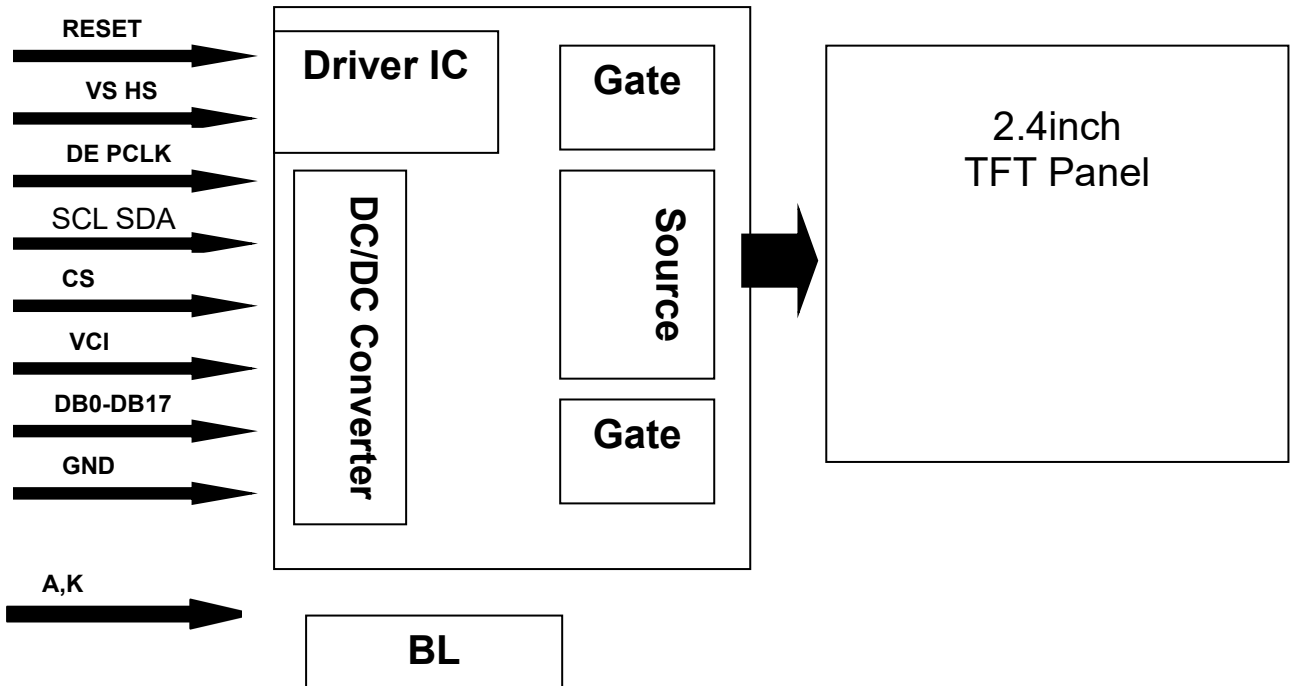



5 INTERFACE TIMING

5.1 System Bus Read/Write Characteristics.

The timing chart of RGB interface DE mode is shown as follows.

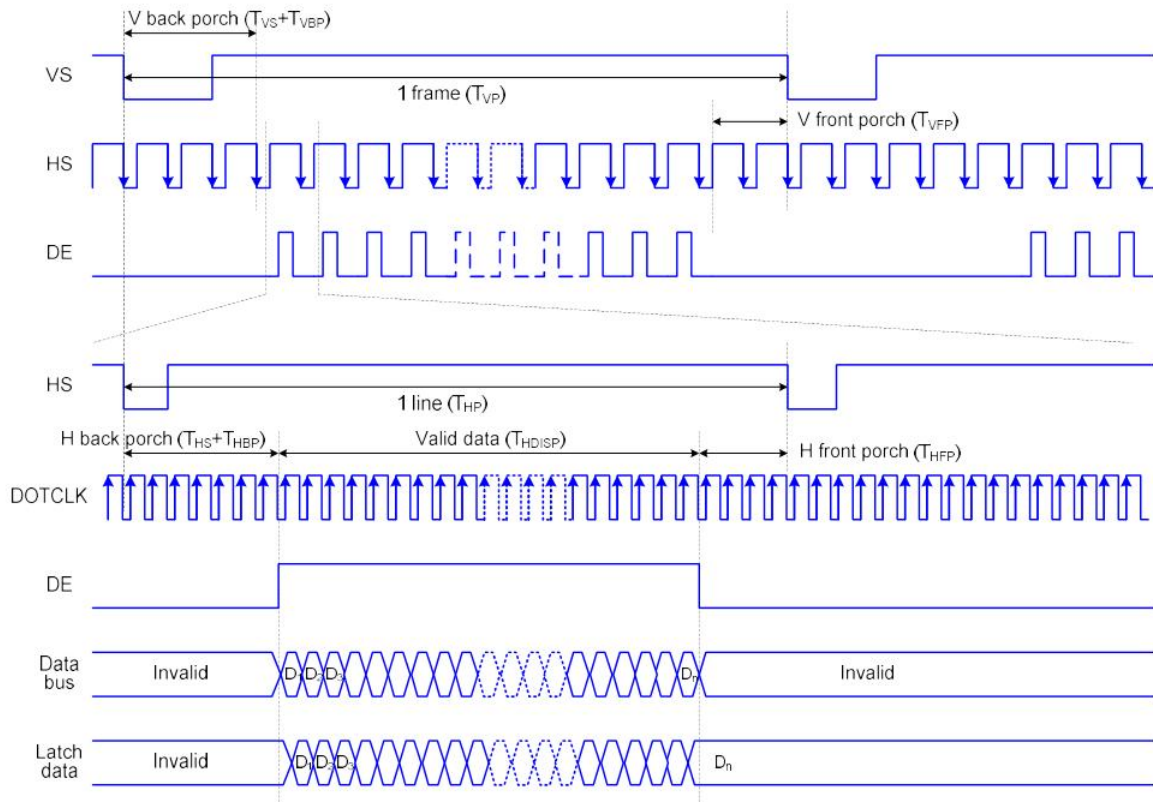

Note: The setting of front porch and back porch in host must match that in IC as this mode.

Timing Chart of Signals in RGB Interface DE Mode



深圳市高信技术有限公司

Shenzhen G&X Technology Co., Ltd

3-SPI Serial Data Transfer Interface Characteristics:

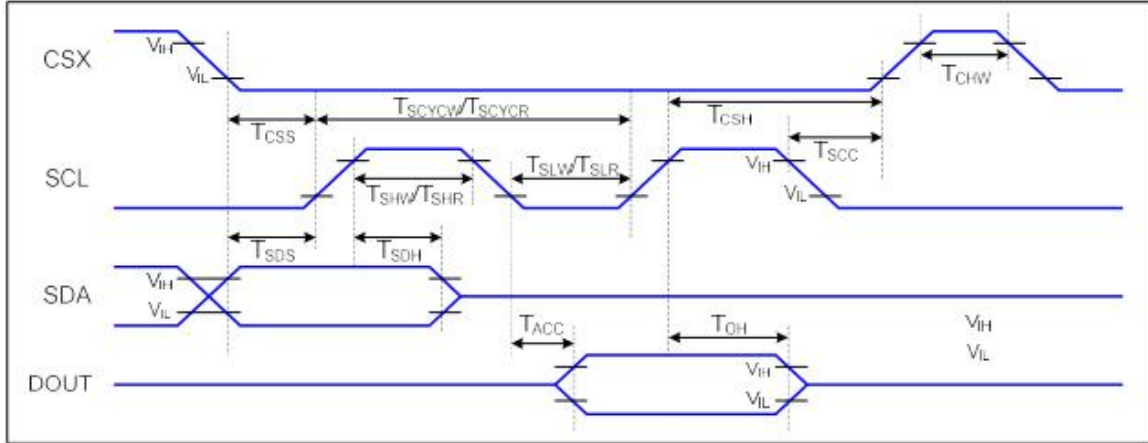

3-SPI Interface Timing Characteristics

VDDI=1.8V, VDDA=2.8V, AGND=DGND=0V, Ta=25 °C

Signal	Symbol	Parameter	Min	Max	Unit	Description
CSX	T _{CSS}	Chip select setup time (write)	15		ns	
	T _{CSH}	Chip select hold time (write)	15		ns	
	T _{CSS}	Chip select setup time (read)	60		ns	
	T _{SCC}	Chip select hold time (read)	65		ns	
	T _{CHW}	Chip select "H" pulse width	40		ns	
SCL	T _{SCYCW}	Serial clock cycle (Write)	66		ns	
	T _{SHW}	SCL "H" pulse width (Write)	15		ns	
	T _{SLW}	SCL "L" pulse width (Write)	15		ns	
	T _{SCYCR}	Serial clock cycle (Read)	150		ns	
	T _{SHR}	SCL "H" pulse width (Read)	60		ns	
	T _{SLR}	SCL "L" pulse width (Read)	60		ns	
SDA (DIN)	T _{SDS}	Data setup time	10		ns	
	T _{SDH}	Data hold time	10		ns	
DOUT	T _{ACC}	Access time	10	50	ns	For maximum CL=30pF
	T _{OH}	Output disable time	15	50	ns	For minimum CL=8pF

3-SPI Interface Characteristics



深圳市高信技术有限公司 Shenzhen G&X Technology Co., Ltd

Power ON/OFF Sequence

VDDI and VDD can be applied in any order.

VDD and VDDI can be power down in any order.

During power off, if LCD is in the Sleep Out mode, VDD and VDDI must be powered down minimum 120msec after RESX has been released.

During power off, if LCD is in the Sleep In mode, VDDI or VDD can be powered down minimum 0msec after RESX has been released.

CSX can be applied at any timing or can be permanently grounded. RESX has priority over CSX.

Note 1: There will be no damage to the display module if the power sequences are not met.

Note 2: There will be no abnormal visible effects on the display panel during the Power On/Off Sequences.

Note 3: There will be no abnormal visible effects on the display between end of Power On Sequence and before receiving Sleep Out command. Also between receiving Sleep In command and Power Off Sequence.

Note 4: If RESX line is not held stable by host during Power On Sequence as defined in the sequence below, then it will be necessary to apply a Hardware Reset (RESX) after Host Power On Sequence is complete to ensure correct operation. Otherwise function is not guaranteed.

The power on sequence:

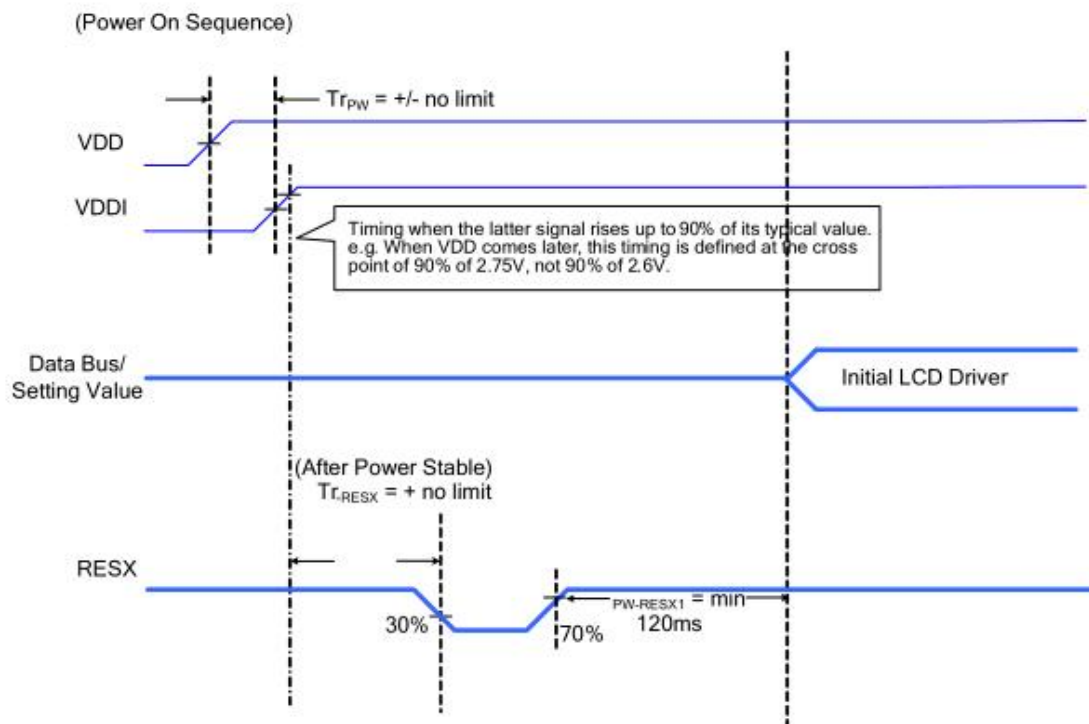



深圳市高信技术有限公司

Shenzhen G&X Technology Co., Ltd

The power off sequence:

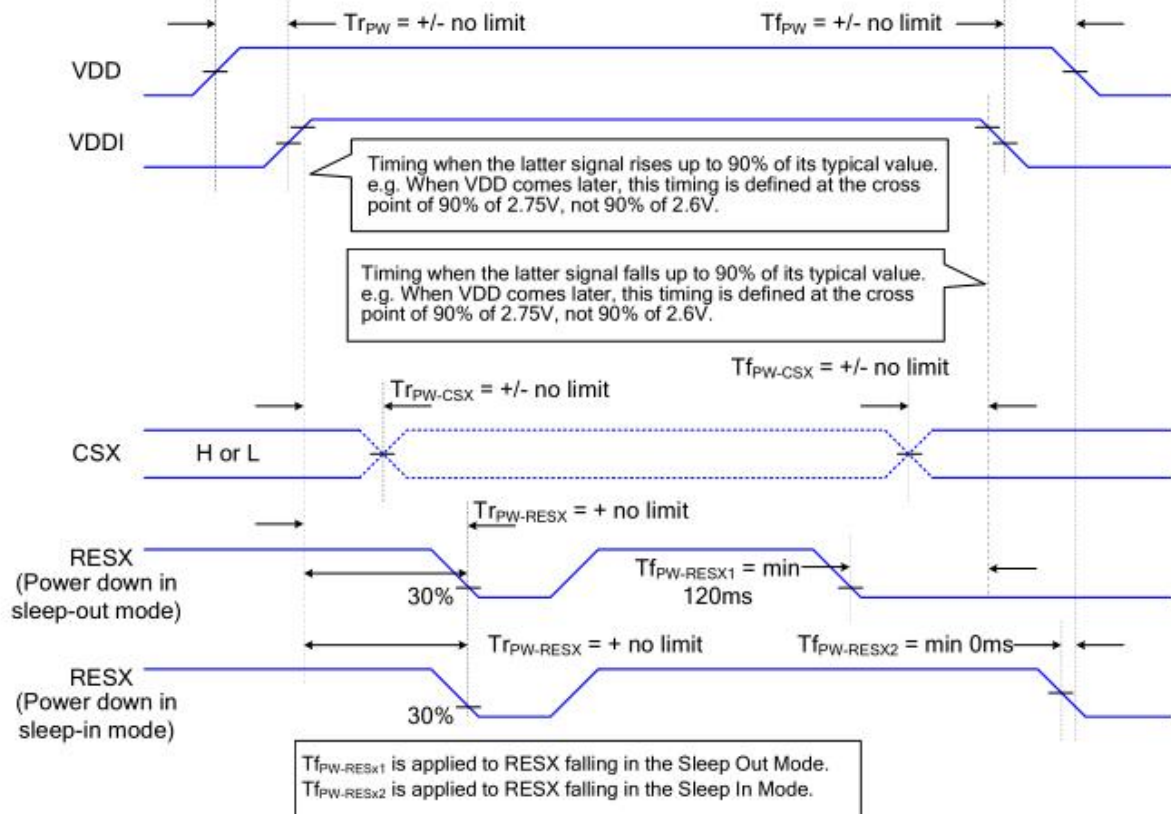



6 Optical Characteristics

Ta=25°C

Item	Symbol	Condition	Min	Typ	Max	Unit	Remark
View Angles	θ_T	$CR \geq 10$	-	80	-	Degree	Note 2
	θ_B		-	80	-		
	θ_L		-	80	-		
	θ_R		-	80	-		
Contrast Ratio	CR	$\theta=0^\circ$	700	900	-	-	Note1 Note3
Response Time	T _{ON}	25°C	-	-	35	ms	Note1 Note4
	T _{OFF}						
Uniformity	U	-	70	80	-	%	Note1 Note6
NTSC	-	-	65	70	-	%	Note 5
Luminance	L		-	300	-	cd/m ²	Note1 Note7

Test Conditions:

1. $V_f=3.2V$, $I_f=60mA$, the ambient temperature is 25°C.
2. The test systems refer to Note 1 and Note 2.



Note 1: Definition of optical measurement system.

The optical characteristics should be measured in dark room. After 5 minutes operation, the optical properties are measured at the center point of the LCD screen. All input terminals LCD panel must be ground when measuring the center area of the panel.

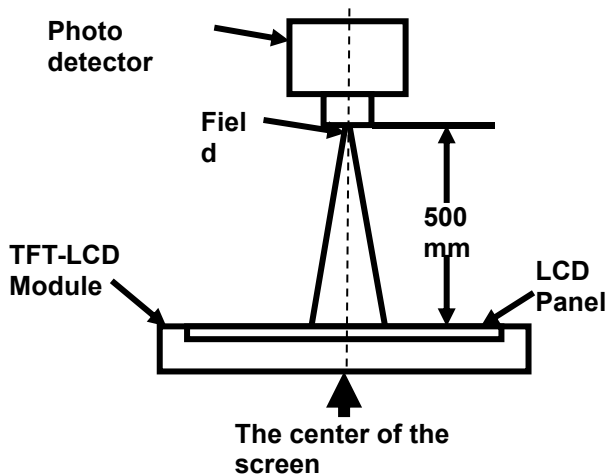

Item	Photo detector	Field
Contrast Ratio	SR-3A	1°
Luminance		
Chromaticity		
Lum Uniformity		
Response Time	BM-7A	2°

Note 2: Definition of viewing angle range and measurement system.

viewing angle is measured at the center point of the LCD by CONOSCOPE(ergo-80).

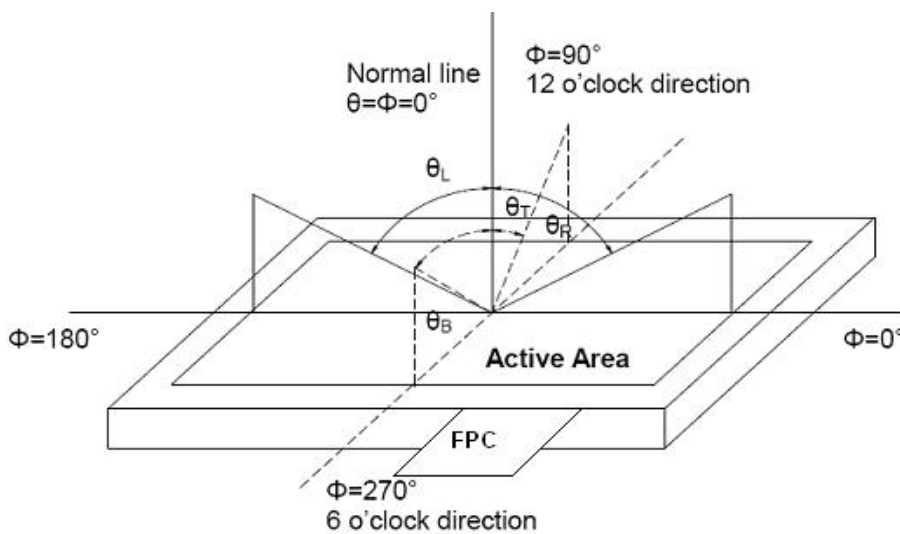

Fig. 1 Definition of viewing angle



深圳市高信技术有限公司

Shenzhen G&X Technology Co., Ltd

Note 3: Definition of contrast ratio

$$\text{Contrast ratio (CR)} = \frac{\text{Luminance measured when LCD is on the "White" state}}{\text{Luminance measured when LCD is on the "Black" state}}$$

“White state “:The state is that the LCD should be driven by V_{white} .

“Black state”: The state is that the LCD should be driven by V_{black} .

V_{white} : To be determined V_{black} : To be determined.

Note 4: Definition of Response time

The response time is defined as the LCD optical switching time interval between “White” state and “Black” state. Rise time (T_{ON}) is the time between photo detector output intensity changed from 90% to 10%. And fall time (T_{OFF}) is the time between photo detector output intensity changed from 10% to 90%.

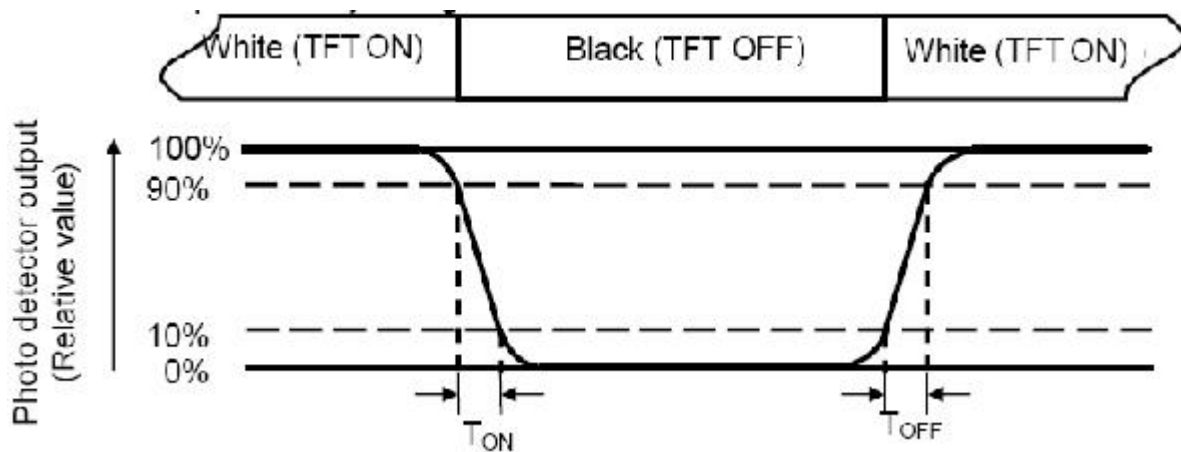

Note 5: Definition of color chromaticity (CIE1931)

Color coordinates measured at center point of LCD.



Note 6: Definition of Luminance Uniformity

Active area is divided into 9 measuring areas (Refer Fig. 2). Every measuring point is placed at the center of each measuring area.

$$\text{Luminance Uniformity (U)} = L_{\min} / L_{\max}$$

L-----Active area length W----- Active area width

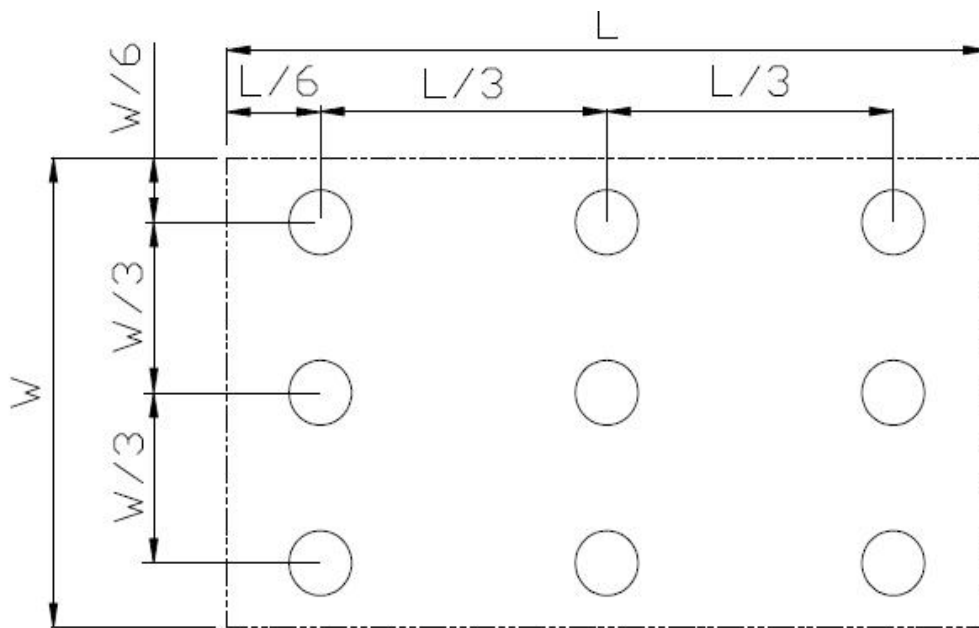

Fig. 2 Definition of uniformity

L_{\max} : The measured maximum luminance of all measurement position.

L_{\min} : The measured minimum luminance of all measurement position.

Note 7: Definition of Luminance:

Measure the luminance of white state at center point.



7 Environmental / Reliability Test

Item	Condition	Time (hrs)	Assessment
High temp. Storage	80°C	120	No abnormalities in functions and appearance
High temp. Operating	70°C	120	
Low temp. Storage	-30°C	120	
Low temp. Operating	-20°C	120	
Humidity	40°C/ 90%RH	120	
Thermal Shock(Non-operation)	-20°C ← 25°C →70°C (0.5 hour ← 5 min → 0.5 hour)	10cycles	

Remark:

- 1.The test samples should be applied to only one test item.
- 2.Sample size for each test item is 1~10pcs.
- 3.In case of malfunction defect caused by ESD damage, if it would be recovered to normal state after resetting, it would be judged as a good part.



深圳市高信技术有限公司

Shenzhen G&X Technology Co., Ltd

8 Mechanical Drawing

12345678

ABCDEF

玻璃靠上居中组装

标记	DESCRIPTION (描述)	REVISER (修改人)	DATE (日期)
△0	新版发行	FLQ	2022.05.09
△1			
△2			
△3			

LED CIRCUIT DIAGRAM:

I_f=80mA, V_f=3.0V (Typ)

TP PIN:	
1	GND
2	TP_INT
3	TP_SDA
4	TP_SCL
5	TP_RESET
6	TP_VCI
7	GND

TPIN:SYMBL	
1	LEDA
2	LEDK
3	LEDK
4	GND
5	VCI
6	RESET
7	NC
8	NC
9	SDA
10	SCK
11	CS
12	PCLK
13	DE
14	VSYNC
15	HSYNC
16	33DR0~DR17
34	GND
35	TP_INT
36	TP_SDA
37	TP_SCL
38	TP_RESET
39	TP_VCI
40	GND
SSPI+18RGB	

ABCDEF

12345678

深圳市高信技术有限公司

NAME	DATE	Pro(3):	GENERAL: #02	SIZE: A4
DESIGNED:		UNIT: MM	TOLERANCE: Angle=1°	SCALE: 1:1
CHECKED:		PROJECT NO.	GX024-40RB-A1	SHEET: 1/1
APPROVED:		PART NO.		REV: V00

Notes:

- Unit:mm.
- .X: Modification rev. number.
- All radii without dimension R0.3mm.
- All draft angles to be 1.5°.
- Unspecified Tolerances is : ±0.20mm.
- Driver IC: S17796J
- LCD Driver Voltage :
- Color : White
- Operating Temperature : -20° --- +70° C
- Storage Temperature : -30° --- +80° C
- Requirements on Environmental Protection: ROHS HSF



深圳市高信技术有限公司

Shenzhen G&X Technology Co., Ltd

9 Precautions For Use of LCD Modules

9.1 Handling Precautions

9.1.1.1 The display panel is made of glass. Do not subject it to a mechanical shock by dropping it from a high place, etc.

9.1.1.2 If the display panel is damaged and the liquid crystal substance inside it leaks out, be sure not to get any in your mouth, if the substance comes into contact with your skin or clothes, promptly wash it off using soap and water.

9.1.1.3 Do not apply excessive force to the display surface or the adjoining areas since this may cause the color tone to vary.

9.1.1.4 The polarizer covering the display surface of the LCD module is soft and easily scratched. Handle this polarizer carefully.

9.1.1.5 If the display surface is contaminated, breathe on the surface and gently wipe it with a soft dry cloth. If still not completely clear, moisten cloth with one of the following solvents:

- Isopropyl alcohol
- Ethyl alcohol

Solvents other than those mentioned above may damage the polarizer. Especially, do not use the following:

- Water
- Ketone
- Aromatic solvents

9.1.1.6 Do not attempt to disassemble the LCD Module.

9.1.1.7 If the logic circuit power is off, do not apply the input signals.

9.1.1.8 To prevent destruction of the elements by static electricity, be careful to maintain an optimum work environment.

9.1.1.9 Be sure to ground the body when handling the LCD Modules.

9.1.1.10 Tools required for assembly, such as soldering irons, must be properly ground.

9.1.1.11 To reduce the amount of static electricity generated, do not conduct assembly and other work under dry conditions.

9.1.1.12 The LCD Module is coated with a film to protect the display surface. Be care when peeling off this protective film since static electricity may be generated.

9.1.1.13 Storage precautions

9.1.1.14 When storing the LCD modules, avoid exposure to direct sunlight or to the light of fluorescent lamps.

9.1.1.15 The LCD modules should be stored under the storage temperature range. If the LCD modules will be stored for a long time, the recommend condition is:

9.1.1.16 The LCD modules should be stored in the room without acid, alkali and harmful gas.

9.2 Transportation Precautions

The LCD modules should be no falling and violent shocking during transportation, and also should avoid excessive press, water, damp and sunshine.